



Volley Enclosure Box

installation guide

July 2024

Volley Enclosure Box

1. Assemble the Height-Adjustable Table.
2. Position the Volley Enclosure Box in upright position on the floor.
3. Remove the Grommet Cover as shown in Figure 1.
4. Unscrew the 2 - #10 11/16" Pan Head, Square Drive Screws as shown in Figure 2.

Continued on the next page >>

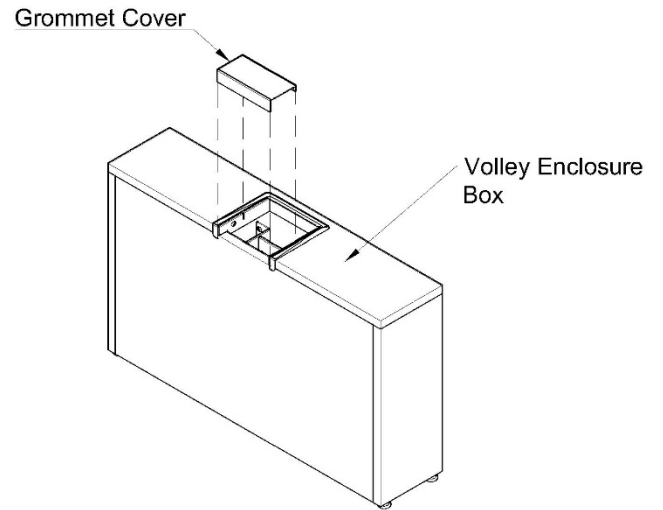

Figure 1

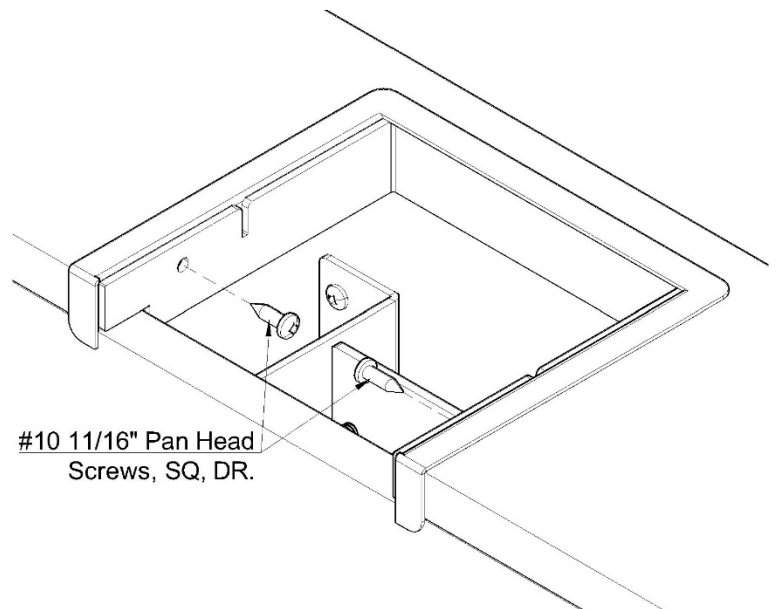
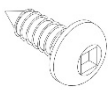

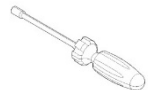

Figure 2

Tools & Hardware Needed

		
#10 11/16" Pan Head Screw, SQ, DR.	#10 11/16" Square Bit	Screwdriver

Volley Enclosure Box

- 5. Remove the Grommet Flange as shown in Figure 3.
- 6. Remove the Leg Box Cover as shown in Figure 4.

Continued on the next page >>

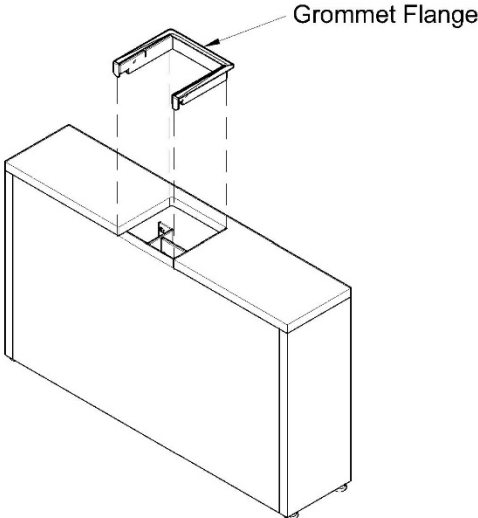

Figure 3

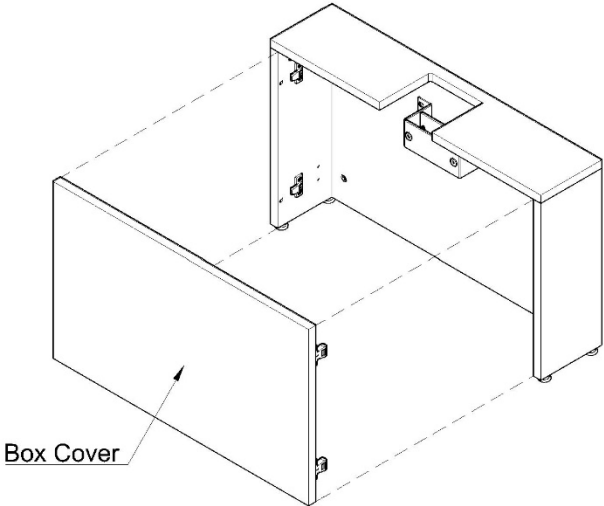

Figure 4

Tools & Hardware Needed

Volley Enclosure Box

7. Unscrew the 6 - #10 11/16" Pan Head, Square Drive Screws and remove the U-Bracket from the Volley Enclosure Box as shown in Figure 5.
8. Unscrew the 2 - JCB-B Assembly Bolt, 1/4-20 Thread, 70 MM Long Bolts from the U-Bracket as shown in Figure 6.

Continued on the next page >>

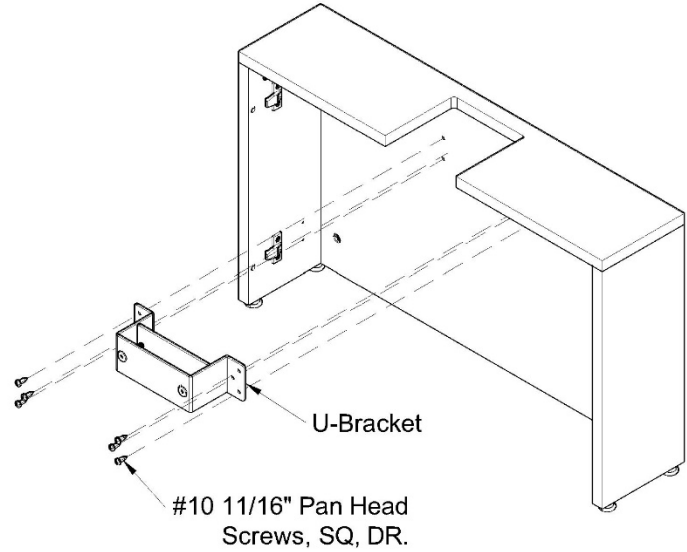

Figure 5

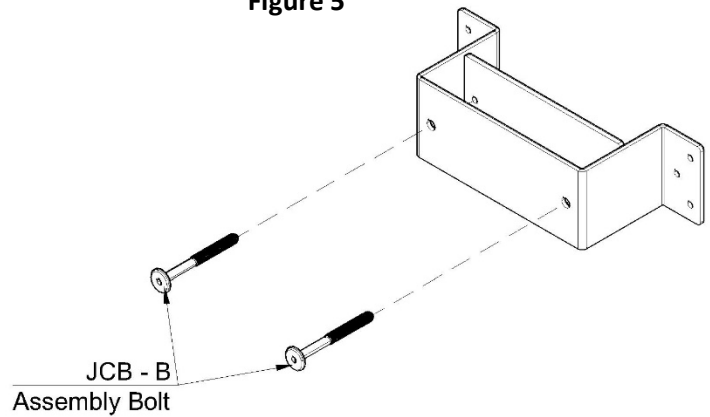
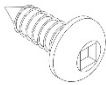

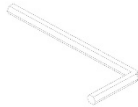
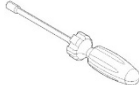

Figure 6

Tools & Hardware Needed

				
#10 11/16" Pan Head Screw, SQ. DR.	JCB-B Assembly Bolt, 1/4-20 Thread, 70 MM Long	#10 11/16" Square Bit	Allen Key	Screwdriver

Volley Enclosure Box

- 9. Remove the Plate as shown in Figure 7.
- 10. Place the U-Bracket around the Table Leg as shown in Figure 8. Place the Plate in the back of the leg and fasten the 2 - JCB-B Assembly Bolt, 1/4-20 Thread, 70 MM Long Bolts through the U-Bracket to the Plate.

Continued on the next page >>

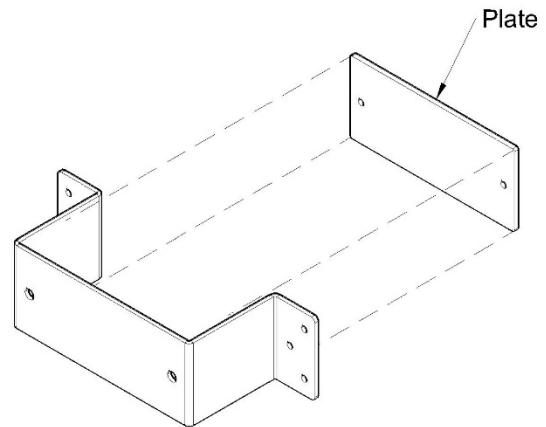

Figure 7

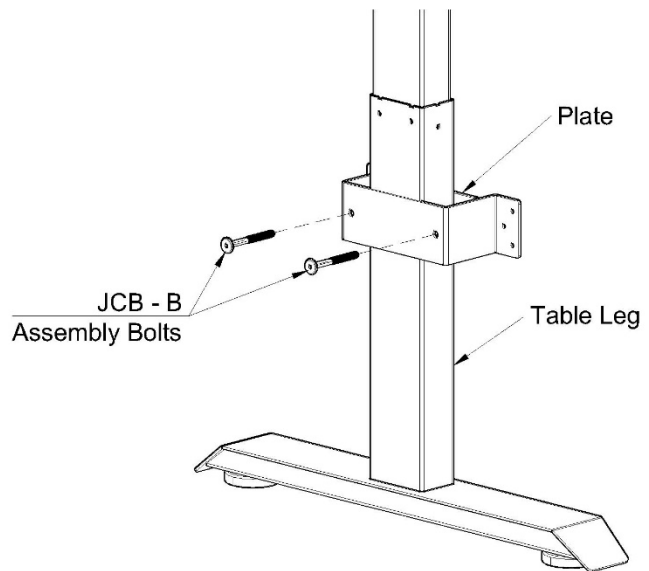

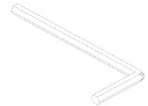

Figure 8

Tools & Hardware Needed

	
JCB-B Assembly Bolt, 1/4-20 Thread, 70 MM Long	Allen Key

Volley Enclosure Box

- 11.** Bring the Volley Enclosure Box and place it around the Table Leg. Adjust the U-Bracket so that the screw holes align with the Pre-Drilled Holes inside the box. Drive the 6 - #10 11/16" Pan Head, Square Drive Screws and fasten the U-Bracket with the Box as shown in Figure 9.
- 12.** Bring the Box Cover and close the open side of the Volley Enclosure box as shown in Figure 10.

Continued on the next page >>

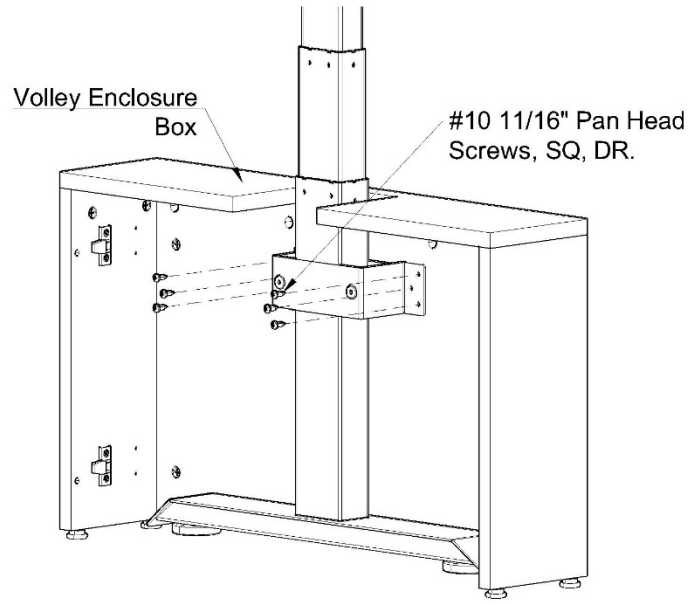

Figure 9

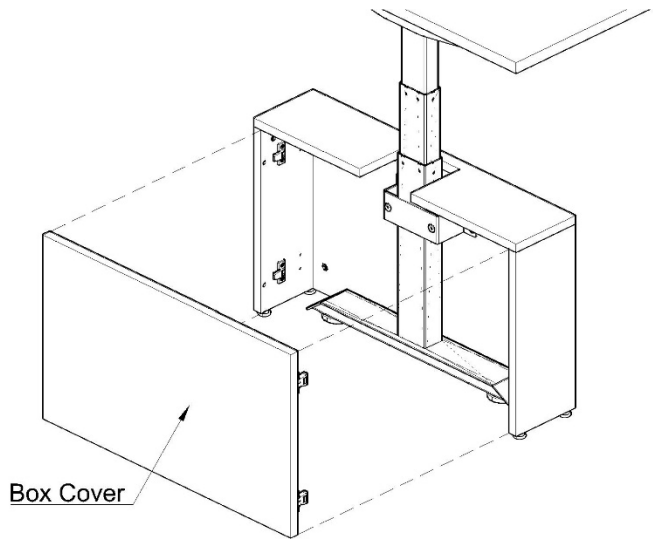
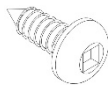

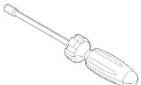

Figure 10

Tools & Hardware Needed

		
#10 11/16" Pan Head Screw, SQ. DR.	#10 11/16" Square Bit	Screwdriver

Volley Enclosure Box

- 13.** Bring the Grommet Flange and place it in the cut-out of the Box Top as shown in Figure 11.
- 14.** Drive the 2 - #10 11/16" Pan Head, Square Drive Screws through the Grommet Flange Holes into the Box Top as shown in Figure 12.

Continued on the next page >>

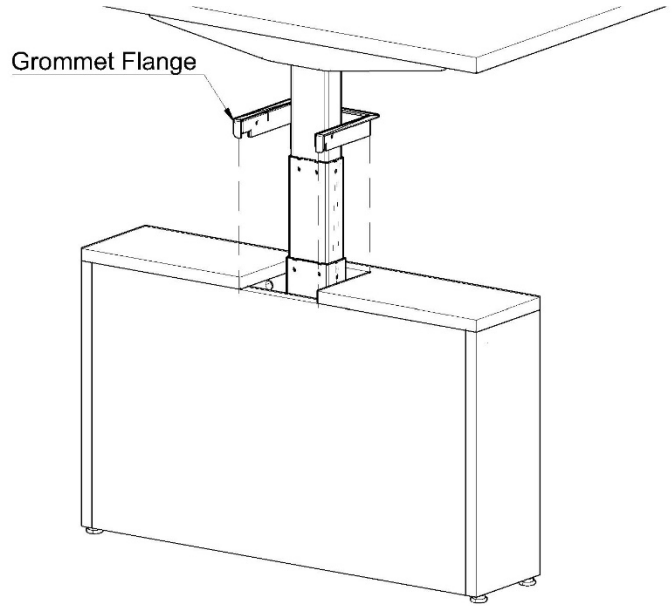

Figure 11

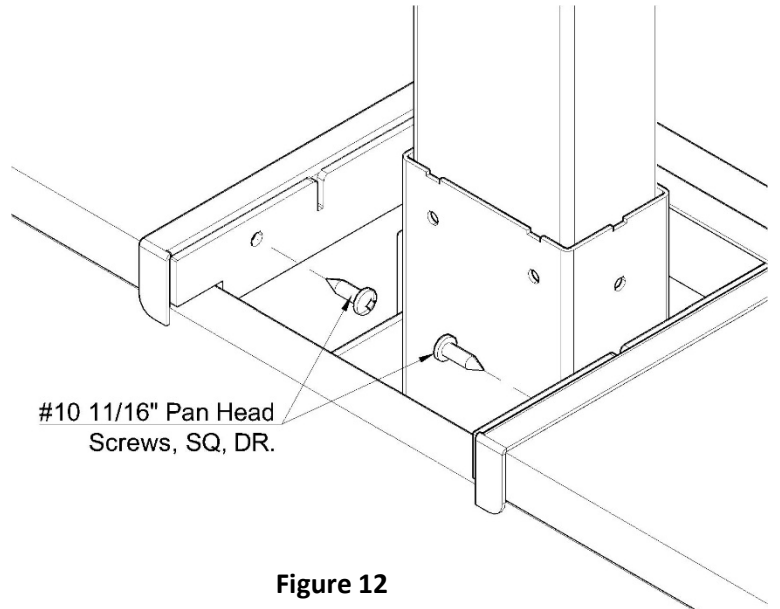
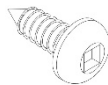
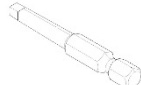
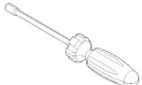

Figure 12

Tools & Hardware Needed

		
#10 11/16" Pan Head Screw, SQ. DR.	#10 11/16" Square Bit	Screwdriver

Volley Enclosure Box

- 15. Place the Cover of the Grommet Flange in its position as shown in Figure 13.
- 16. Repeat the above steps for the other Table Leg.

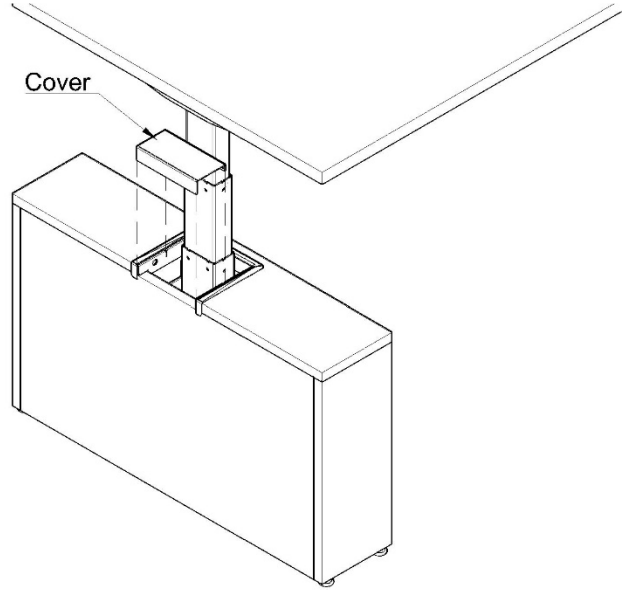

Figure 13

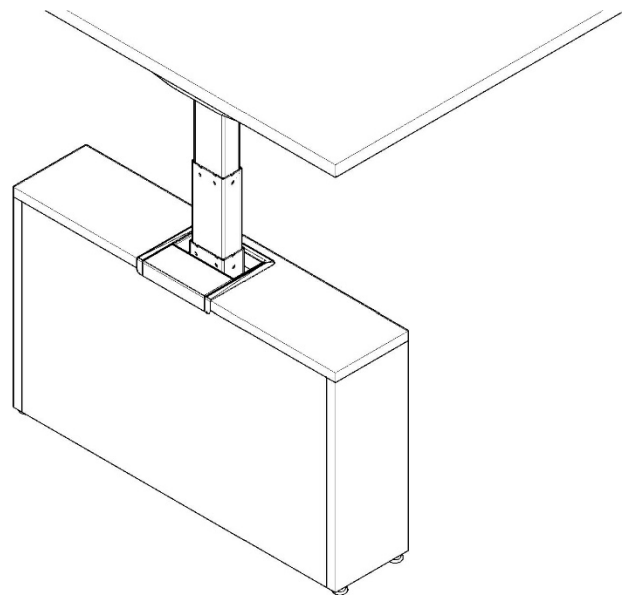

Figure 14

Tools & Hardware Needed

tayco®

tayco.com

07/2024